

P.A.P. (Piles and Arched Panel) Dam

Kinki Regional Construction Bureau
Ministry of Land, Infrastructure, Transport and Tourism

1. Outline of the Construction Site

In the Sasaokawa valley, a tributary of the Managawa river in the Kuzuryu River system, Sasaokawa dam, a multi-purpose dam, had been constructed in order to prevent flood discharge and to generate electricity. In the dam reservoir sedimentation had been taking place more rapidly than projected so that the storage capacity of the reservoir has been getting smaller than expected.



Figure 1 Location of Sasaogawa 3rd Dam

A P.A.P. dam has therefore been build 1 km upstream of the reservoir in order to prevent excess sediment load from flowing into the reservoir. Average riverbed slope is 1/50 around the dam site. The mode of transportation of solid materials is therefore defined not mass-movement but individual particle motion. The size of mobile materials ranges from 0.5 to 1.5 meters in diameter. The bed rock is composed of soft rock.

2. Technologies employed

A P.A.P. dam is characterized by piers with piling foundation and pre-cast arch-shaped concrete panels, PC panels in short, stack in layers between piers. The arch action derived from panels between the piers works against earth pressure.

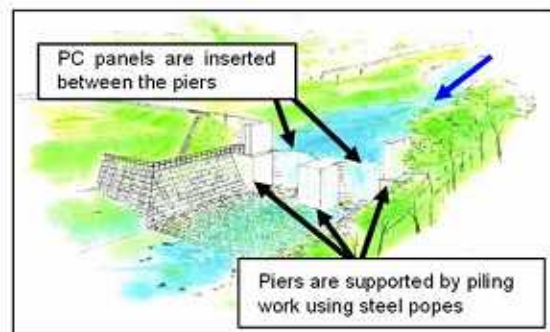

Figure 2 Structural Design of P.A.P Dam

A PC panel has advantage in large workability and function because of its size. Furthermore, little impact in the dam stability is identified if a few panels were broken.

The PAP method contributes to the followings;

1) laborsaving

because of the size of PC panels it is easy to transport and to carry at sites.

2) short term of works

Prefabricated PC panels can be supplied on demand. Contractors can therefore acquire panels while building a dam.

3) lower cost

Construction cost can be reduced along with the reduction in concrete volume, earthwork volume, labor cost and term of works.

4) lesser environmental impacts

Lesser earthwork volume results in lesser requirements in the area of cutting works and soil disposal.

5) aesthetic design

The arch-shaped panels of dam body create beautiful and comfortable falls which could fit natural environment in a valley.

6) easy maintenance and effective sediment discharge management

PC panels can be, in case of either disaster or aging, replaced and removed if much more sediment supply is required.

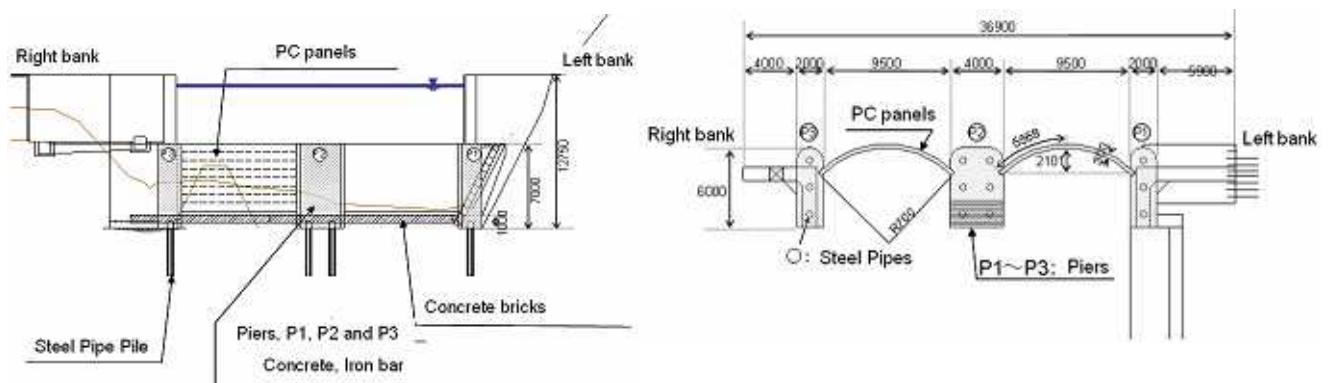

Figure 3 Plane View of P.A.P. Dam

3. Justification of the P.A.P. Dam in this case

The dam construction project should be implemented avoiding snow season so that a specific technology which could shorten the term of works was required.

With regard to the earthwork, a proper technology, other than the one for gravity-type dam, which could lessen the volume of earthwork was required since it was assessed that a gravity-type dam required a massive earthwork at the right bank which was composed of thick talus deposit.

Long distance between the dam site and the logistic support base in the nearest town

prevented the project to employ ordinary technologies. The distance between the site and the town was as far as 30 km and took more than one hour to transport bulky materials such as ready-mixed concrete and other resources.

Taking into account the above all the conditions it was decided that P.A.P. dam technology was the most appropriate.



Photograph 1 Front View of the P.A.P. Dam (under construction)

4. Problems to be solved

The P.A.P. dam is good enough to resist earth pressure and hydro-pressure, but it is not yet certain whether it can resist impact forces due to hits by debris flows.

Since the reaches in which the dam is located is not dominated by the massive sediment transportation, no study on possible impacts of debris flows was not conducted, but if a dam of this type is constructed in the reaches dominated by the massive sediment transportation, detail study on the impacts and effects must be conducted.

In addition, study on the hydraulic effects of this arch-shaped dam, focusing on the motion of sediment particles and stream line by means of either numerical or hydraulic simulations.